



## **1½ & 2" Cast Iron & Stainless Steel Pump Instruction Manual**

150PBI, 150PI-3, 150POI, 200PI-3, 200PI6PRO, 200PIH-5, 200PIH5E, 200PBI, 200POI, 200PI6CLT, 200PIHY

Read these instructions and the instructions covering the operation of the engine before starting the engine. Do not operate the engine until you have put oil in the engine crankcase. It is wise to check the oil level each time the gasoline tank is filled. If the pump is used only occasionally, check oil and gasoline before starting engine.

Do not run the pump dry. Always fill the pump body with water (or liquid to be pumped) before starting pump. It is not necessary to drain the pump body after use, unless there is a danger of freezing.

Use a regular grade of gasoline (unleaded and uncolored if available). Remove the engine cylinder head after 100 hours of operation and remove the carbon and lead deposits from the combustion chamber and top of the piston.

Make certain that all hose and pipe connections are airtight. An air leak in the suction line may prevent priming and will reduce the capacity of the pump.

Always place the pump as close to the liquid to be pumped as possible. Keep the suction line short and with few bends. Keep the pump and engine on a level foundation. A poor foundation and a heavy suction hose (made heavier when "primed" full of liquid) could result in a pump "down the hole".

There are important instructions regarding preparing the engine for long periods of idleness. (Read the engine instruction manual). Under these conditions, drain the pump completely, turn the engine over a few times and leave all plugs (filter and drain) out of the pump. Always try to store the unit in a heated and dry building.

When pumping dirty water or other liquids containing solids, always use a pump strainer on the end of the suction line. There are no points on the pump which need lubrication. The shaft seal is self-lubricating, and designed to handle clean or dirty liquids.



# DISASSEMBLY INSTRUCTIONS:

1. Remove bolted clamp from shaft. Remove (4) bolts holding motor or Bearing Pedestal to the adapter plate.



2. Remove (6) nuts and lock washers holding adapter plate to housing. Using a screwdriver behind the side tabs, gently pry the adapter loose. Remove impeller, drive sleeve and seal assembly.



3. Remove two stainless steel flat head screws and remove wear plate. Replace the wear plate when there are surface grooves or excessive wear.

When reassembling, make sure there is no foreign material between the wear plate and the pump housing that would prevent the wear plate from lying flat.

4. Remove the seal and spring from the impeller and drive sleeve. Inspect the surface of the impeller sleeve. The surface can be cleaned with very fine sandpaper (#400) or if excessively worn or grooved, the impeller should be replaced. Remember, a worn impeller can cause an out of balance condition resulting in vibration and seal wear.

Always install a new seal assembly onto impeller before reassembling pump. It is very important not to scratch or mark the black carbon surface of the seal assembly.

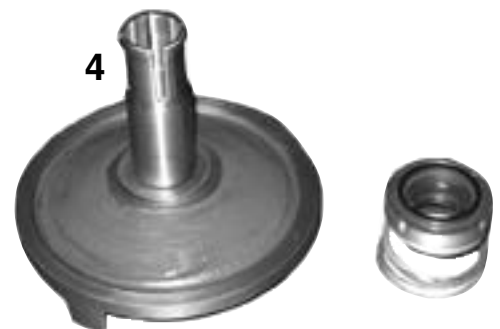
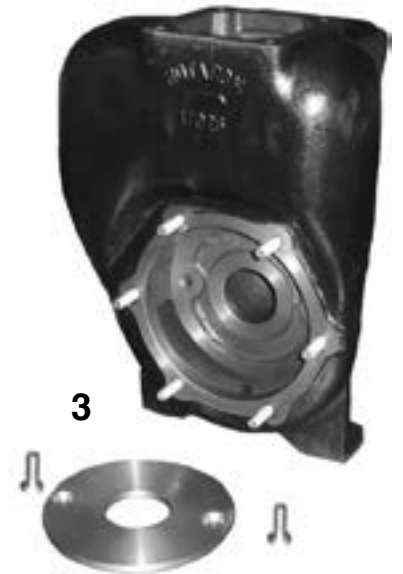



5. Remove the white ceramic seal and rubber cup from the rear adapter. Clean the recess opening with sandpaper or wire brush.

Install the new seal half.

Very important to not scratch or mark the white ceramic seal surface. It is usually helpful to apply a small amount of lubrication to the rubber cap and then press the seal into position, using your two thumbs or arbor press to press in evenly. Make sure the seal is in position straight and true to prevent seal wobble.



6. A shim is used to set the clearance between the impeller and wear plate. Any shim with a thickness of .030/.040 can be used. An ideal shim is a 1/2" wide piece of No. 21 gauge sheet metal.

Place the impeller and seal half assembly in position with impeller face against the banding material.



7. Install rear adapter using a new adapter gasket. Tighten (6) nuts.

8. Install pump to gas engine or bearing pedestal and tighten bolts.

Install bolted clamp and tighten bolts. The clamp bolts should be very tight. They should also be tightened equally so the space from side to side between clamps is equal for balance and to prevent vibration.

After all bolts are tight, grip the banding material and pull out.

After shim is removed the pump should turn freely.

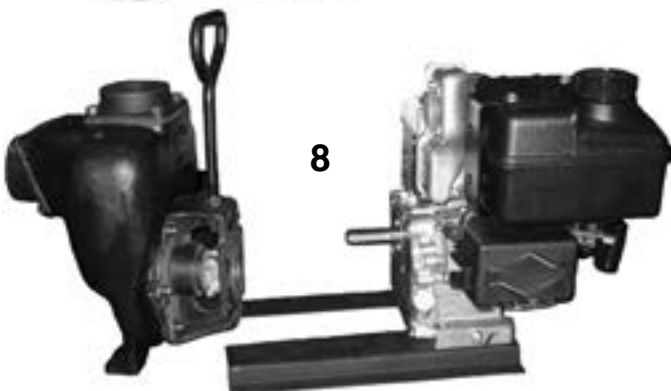

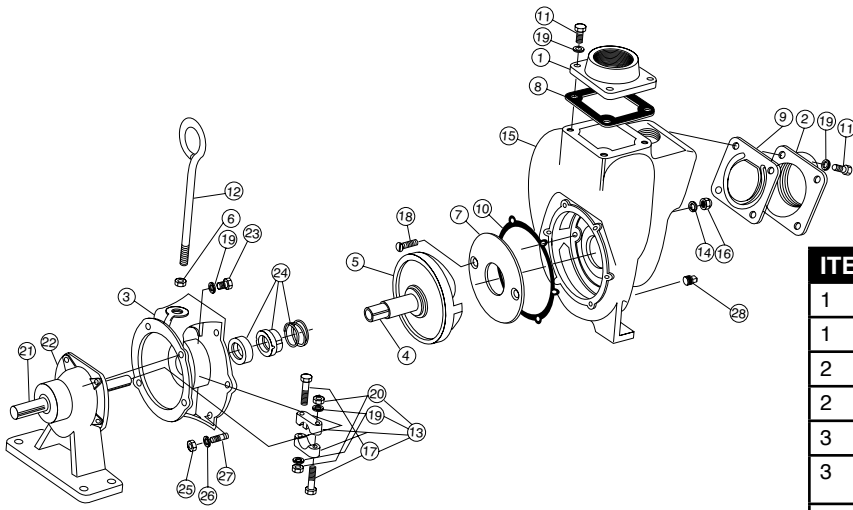

ITEM	PART NO.	DESCRIPTION
1	17000SS	Flange-Outlet 2"
2	17002SS	Flange-Inlet 2"
3	17004SS	Adapter-Gas Engine
3	17046SS	2" C-Flange Adapter
4	17005SS	Sleeve-Drive 5/8" Stainless Steel
4	17006SS*	Sleeve-Drive 3/4" Stainless Steel
4	17007SS	Sleeve-Drive 7/8" Stainless Steel
5	17008SS*	Impeller Stainless Steel
5	17008-4.1SS	Impeller-4.1"
5	17008-4.6SS	Impeller-4.6"
6	17010	Nut, Hex 1/2" - 13 UNC
7	17011SS*	Plate-Wear Stainless Steel
8	17014	Gasket-Outlet viton
9	17017	Gasket-Check Valve Assembly viton
10	17018*	Gasket-Adapter
11	17019	Capscrew 5/16" - 18 x 3/4"
12	17022	Handle
13	17023	Clamp-5/8", 3/4" Shaft
14	17024	Clamp-7/8" Shaft SS
14	17025*	Wear Plate Gasket
15	17026SS	Pump Housing Stainless Steel
16	17027	Nut, Acorn 5/16" - 18
17	17029	Capscrew 5/16" - 18 x 1 3/4"
18	17030SS*	Flat Head 82° C'Sink Screw S.S.
19	V10118	Lock Washer 5/16"
20	V10119	Nut, 5/16" - 18 Hex. S.S.
21	12883	Bearing Only with Shaft -3/4"
22	12882	Bearing Pedestal Assembly with 3/4" shaft
23	17040	Cap Screw 5/16" - 24 NF
24	17035SS*	Viton Seal Assembly
25	V10119	Nut, 5/16" - 18 Hex. S.S.
26	V10118	Washer, 5/16" Lock S.S.
27	17042	Stud
28	17032SS	1/4" Drain Plug S.S.
N/S	17020/17021	SS Flap Washer (Sm) / SS Flap Washer(Lg)
N/S	17033	Z Rails
N/S	17100SS	Pump Repair Kit (Items marked *)

ITEM	PART NO.	DESCRIPTION
1	17000	Flange-Outlet 2"
1	17001	Flange-Outlet 1 1/2"
2	17002	Flange-Inlet 2"
2	17003	Flange-Inlet 1 1/2"
3	17004	Adapter-Gas Engine
3	17046	C-Flange Adapter for Close Coupled Electric Drive Pump
3	17049	C-Flange Hydraulic Motor Adapter (cast iron)
N/S	17055	Hydraulic Shaft Sleeve Adapter
N/S	17214	Hydraulic Adapter Bearing
N/S	HY10131	Gresen Hydraulic Motor
N/S	17600	Hydraulic Motor Conversion Assembly
4	17005	Impeller Drive Sleeve- 5/8" Shaft Sleeve
4	17006*	Impeller Drive Sleeve- 3/4" Shaft Sleeve
4	17007	Impeller Drive Sleeve- 7/8" Shaft Sleeve
5	17008*	Impeller-5"
5	17008-4.6	Impeller-4.6"
5	17008-4.1	Impeller-4.1"
6	17010	Nut, Hex 1/2" - 13 UNC
7	17011	Wear plate
8	17013	EPDM Gasket
9	17016	Gasket-Checkvalve Assembly
10	17018*	Gasket Adapter
11	17019	Capscrew 5/16" - 18 x 3/4"
12	17022	Handle
13	17023	Clamp 5/8", 3/4" Shaft Assembly
14	17024	Clamp 7/8" Shaft Assembly
14	17025*	Gasket-Wear Plate
15	17026	Pump Housing
16	17027	S.S. Nut, Acorn 5/16" - 18
17	17029	Cap Screw 5/16" x 18- 1 3/4"
18	17030*	Flat Head 82° C Screw
19	V10118	Lock Washer 5/16"
20	V10119	Nut, 5/16" - 18 Hex. S.S.
21	12883	Bearing Shaft Assembly
22	12882	Bearing Pedestal Assembly
23	17040	Capscrew 5/16" - 24 NF
24	17028	Seal Assembly (EPDM)
25	17035*	Viton Seal Assembly
25	V10119	Nut 5/16" - 18 UNC S.S. Hexnut
26	V10118	Washer, 5/16" Lock S.S.
27	17042	Stud
28	17032	1/4" Drain Plug
N/S	17020	S.S. Flap Washer (Small)
N/S	17021	S.S. Flap Washer (Large)
N/S	17033	Z-Rails (1 pair)
N/S	17100	Pump Repair Kit (Items marked *)