

# HIGH PRESSURE DIAPHRAGM PUMP

## 9915-D1063

### FEATURES

- Black oxide aluminum heads, manifold, and case.
- Three Duramax diaphragms, crown shaped pistons, and double piston rings.
- Valves: 316 stainless steel spherical profiled valve poppet.
- Inlet Port: 1-1/2"/40 mm
- Outlet Port: 3/4" NPT
- Max Fluid Temp: 140°F/60°C
- Weight: 57.8 lbs/25.3 kg



### PERFORMANCE INFORMATION

PRESSURE PSI	RPM							
	400		450		500		550	
	GPM	HP	GPM	HP	GPM	HP	GPM	HP
30	21.1	0.4	23.8	0.5	26.4	0.5	29.1	0.6
290	20.9	4.1	23.5	4.7	26.1	5.2	28.7	5.7
580	20.6	8.2	23.2	9.2	25.7	10.2	28.3	11.2
725	20.4	10.1	22.9	11.4	25.5	12.6	28.0	13.9

PRESSURE BAR	RPM							
	400		450		500		550	
	LPM	KW	LPM	KW	LPM	KW	LPM	KW
2	80.0	0.3	90.0	0.4	100.0	0.4	110.0	0.4
20	79.0	3.1	88.9	3.5	98.7	3.9	108.0	4.3
40	77.9	6.1	87.6	6.9	97.4	7.6	107.0	8.4
50	77.1	7.6	86.7	8.5	96.4	9.5	106.0	10.4

## ORDERING INFORMATION

MODEL NUMBER	DESCRIPTION	MAX FLOW GPM [LPM]	MAX PRESSURE PSI [BAR]	MAX SPEED RPM	POWER HP [KW]	NUMBER OF DIAPHRAGMS
9915-D1063	Pump Assembly 1-3/8" 6-Spline	27.9 [106]	725 [50]	550	13.9 [10.4]	3
9915-KIT1006	Control Unit					
9915-KIT2006	Diaphragm Kit					
9915-KIT2106	Valve Kit					
9915-KIT2206	Pump Kit					
9915-KIT1302	Safety Cone					
9915-KIT1104	Gear Reduction Kit					

## DIMENSIONAL DATA

9915-D1063

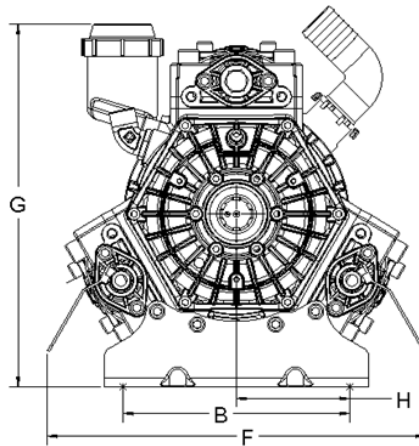
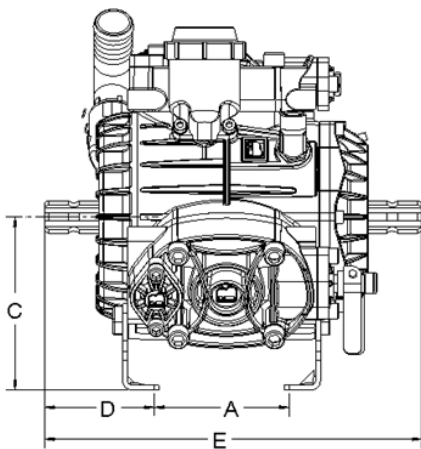

DIM	IN	MM
A	6.3	160
B	9.1	231
C	7.0	177
D	4.4	112
E	15.2	385
F	15.2	286
G	14.6	371
H	4.6	116



375 Fifth Ave NW,  
New Brighton, MN 55112 U.S.  
PHONE: 651-766-6300, 800-424-9776  
FAX: 800-323-6496

[pentair.com](http://pentair.com)

All indicated Pentair trademarks and logos are property of Pentair. Third party registered and unregistered trademarks and logos are the property of their respective owners. Because we are continuously improving our products and services, Pentair reserves the right to change specifications without prior notice. Pentair is an equal opportunity employer.

HYP2101DS (04/15/2021) ©2021 Pentair. All Rights Reserved.