

HIGH PRESSURE DIAPHRAGM PUMP

9915-D1504

FEATURES

- Black oxide aluminum heads, manifold, and case.
- Four Duramax diaphragms, crown shaped pistons, and double piston rings.
- Valves: 316 stainless steel spherical profiled valve poppet.
- Inlet Port: 1-1/2"/40 mm
- Outlet Port: 3/4" NPT
- Max Fluid Temp: 140°F/60°C
- Weight: 79.3 lbs/36 kg



PERFORMANCE INFORMATION

PRESSURE PSI	RPM							
	400		450		500		550	
	GPM	HP	GPM	HP	GPM	HP	GPM	HP
30	26.3	0.5	29.6	0.6	32.9	0.7	36.2	0.7
290	25.7	5.1	29.0	5.8	32.2	6.4	35.4	7.0
580	25.4	10.1	28.5	11.3	31.7	12.6	34.9	13.9
725	25.2	12.5	28.3	14.1	31.5	15.6	34.6	17.2

PRESSURE BAR	RPM							
	400		450		500		550	
	LPM	KW	LPM	KW	LPM	KW	LPM	KW
2	99.6	0.4	112.1	0.4	124.5	0.5	137.0	0.5
20	97.5	3.8	109.6	4.3	121.8	4.8	134.0	5.3
40	96.0	7.5	108.0	8.5	120.0	9.4	132.0	10.4
50	95.3	9.4	107.2	10.5	119.1	11.7	131.0	12.9

ORDERING INFORMATION

MODEL NUMBER	DESCRIPTION	MAX FLOW GPM [LPM]	MAX PRESSURE PSI [BAR]	MAX SPEED RPM	POWER HP [KW]	NUMBER OF DIAPHRAGMS
9915-D1504	Pump Assembly 1-3/8" 6-Spline	38.8 [147]	725 [50]	550	19.3 [14.4]	4
9915-KIT1006	Control Unit Kit 3-Way					
9915-KIT1007	Control Unit Kit 2-Way					
9915-KIT2007	Diaphragm Kit					
9915-KIT2107	Valve Kit					
9915-KIT2207	Pump Kit					
9915-KIT1302	Safety Cone					

DIMENSIONAL DATA

9915-D1504

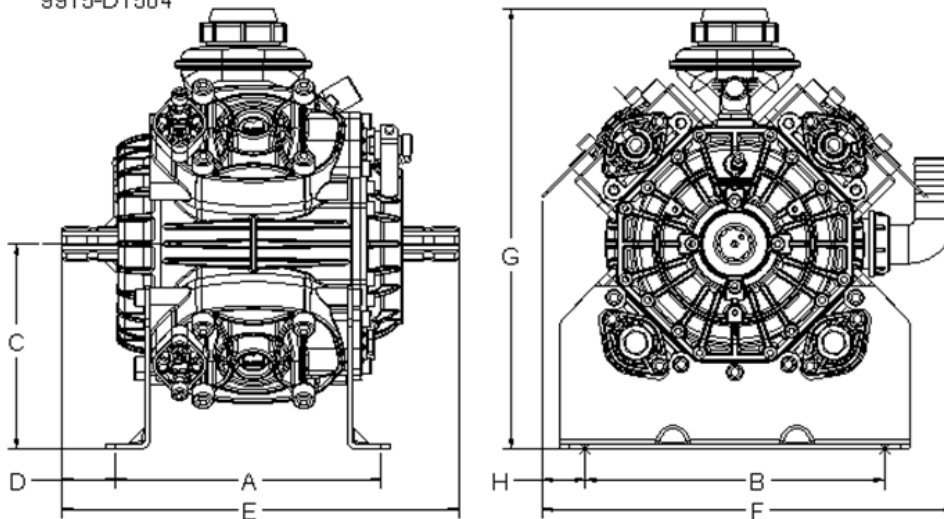

DIM	IN	MM
A	9.6	245
B	11.4	290
C	7.9	200
D	2.3	59
E	15.2	385
F	15.8	401
G	16.9	429
H	1.7	42



375 Fifth Ave NW,
New Brighton, MN 55112 U.S.
PHONE: 651-766-6300, 800-424-9776
FAX: 800-323-6496

pentair.com

All indicated Pentair trademarks and logos are property of Pentair. Third party registered and unregistered trademarks and logos are the property of their respective owners. Because we are continuously improving our products and services, Pentair reserves the right to change specifications without prior notice. Pentair is an equal opportunity employer.

HYP2102DS (04/15/2021) ©2021 Pentair. All Rights Reserved.