

Copyright. All information furnished within this document, electronic file or design correspondence is the property of Den Hartog Industries, Inc. and shall not be used, disclosed to others or copied without the expressed written consent of Den Hartog Industries, Inc.

KEY	PART NUMBER	DESCRIPTION	QTY.
1	12889	END STRINGER-CENTER SUMP	2
2	12890	CENTER STRINGER-CENTER SUMP	4
3	12891	CENTER STRINGER-TALL-CENTER SUMP	2
4	FM1610-SKO-1	FORMED SUPPORT CHANNEL	2
5	19417	TOP PLATE	8
6	19418	SUPPORT CHANNEL	2
7	13691	1610 POWDER COAT PLATE	2

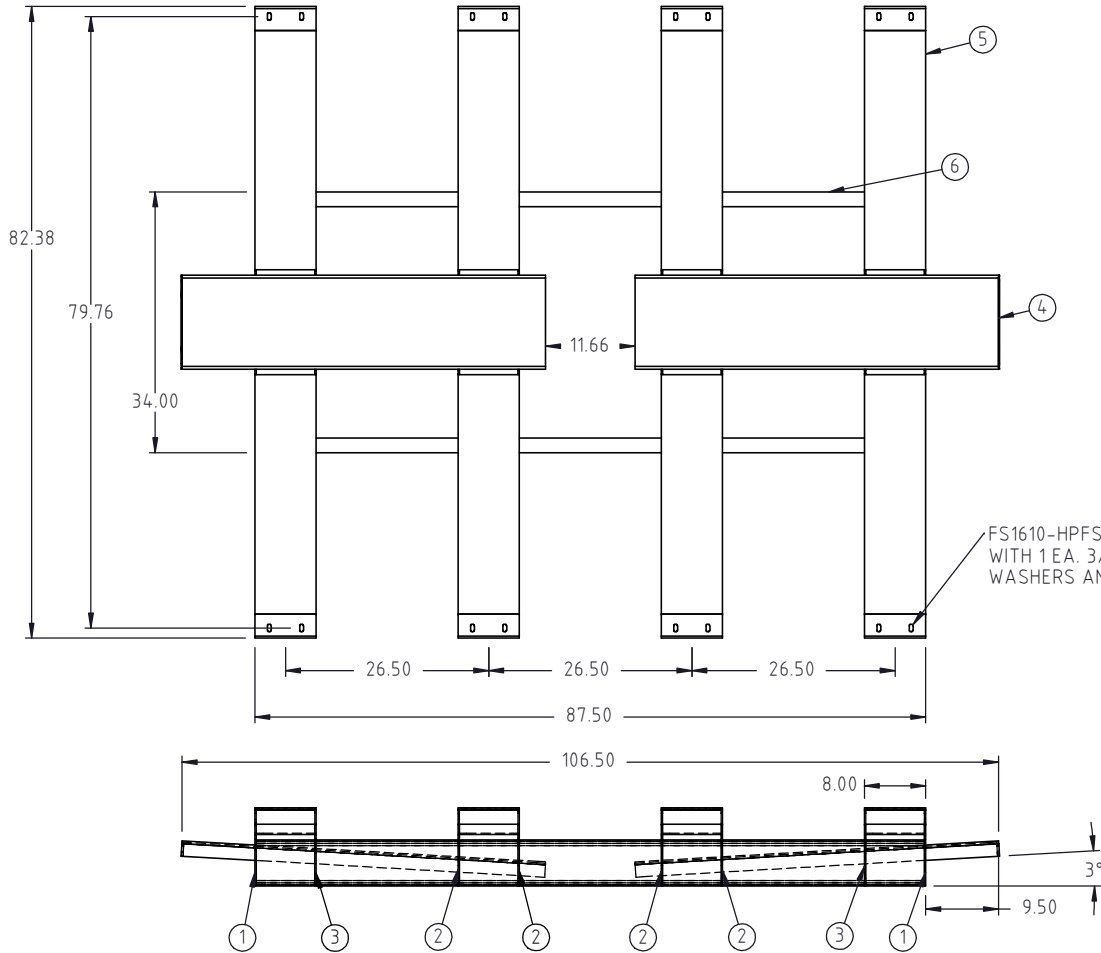

FS1610-HPFS ATTACH TO EACH SLOT WITH 1 EA. 3/8" X 2" HEX BOLT, 2 EA. FLAT WASHERS AND 1 EA. HEX NUT (16 PLACES)

FS19419 RETAINER PLATES ATTACH TO EACH HOLE WITH 1 EA. 3/8" X 1-1/4" HEX BOLT, 2 EA. FLAT WASHERS AND 1 EA. HEX NUT

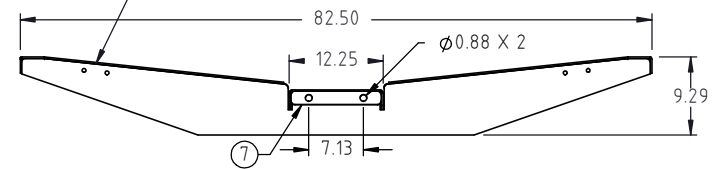

				DRAWN / DATE ADH 6/4/10	MATERIAL
A	POWDER COATING PLATE ADDED TO PRINT	ADH 8/2/12	2465	APPRD. / DATE REH 6/28/10	
REV	DESCRIPTION	BY / DATE	CCN		
ALL DIMENSIONS ARE IN DECIMAL INCHES TOLERANCES UNLESS OTHERWISE SPECIFIED		THIRD ANGLE PROJECTION ANSI 14.5M		SHOT WEIGHT:	NOTES:
POLYETHYLENE		METAL DECIMAL ± .125" FRACTION ± 1/4" ANGLE ± 1°		SHIPPING WEIGHT: 490 LBS	
±1% @ 68°F				FINISH: POWDER COATING, BLACK TILE, 40012	



**Den Hartog**  
INDUSTRIES, INC.

Acc Roto-Mold Injection Molding Blow Molding Sowjoy

4010 HOSPERS DRIVE S. BOX 425, HOSPERS, IOWA 51238-0425

DESCRIPTION	1610 SKID -CENTER SUMP	
SCALE	N.S.	PART NO. FM1610-SKC