

Copyright. All information furnished within this document, electronic file or design correspondence is the property of Den Hartog industries, Inc. and shall not be used, disclosed to others or copied without the expressed written consent of Den Hartog Industries, Inc.

KEY	PART NUMBER	DESCRIPTION	QTY.
1	SJHZ0055C-1	ANGLE, CRADLE 55 GAL.	2
2	SJHZ25/55C-8	END PLATE, CRADLE 25/55 GAL	2
3	HZ0055-CSBS	HZ, SS BAND 55 GAL SINGLE	2
4	BB5/16X3BAG-4	BOLT BAG, 5/16"X3" J-BOLT	1

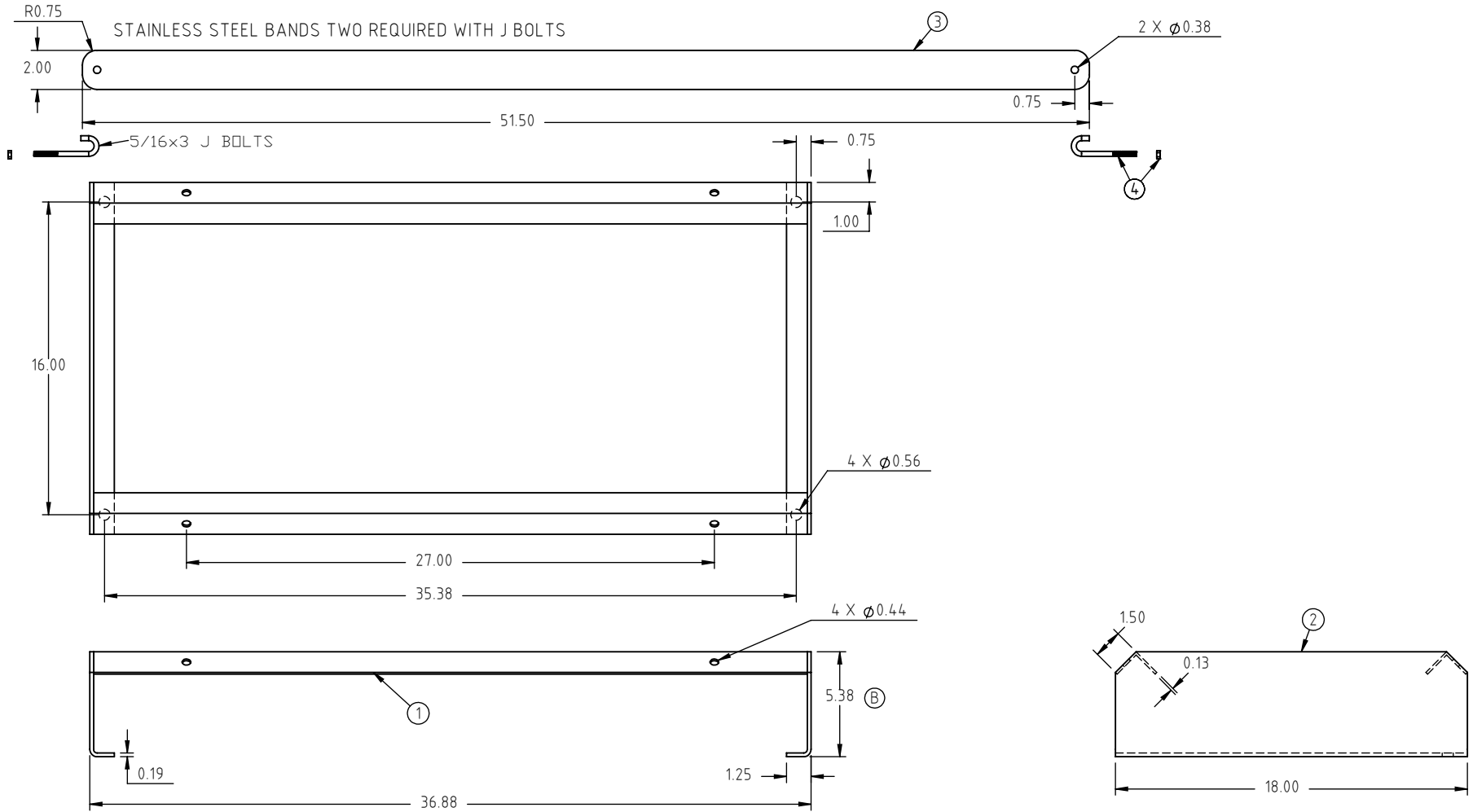

C	DESCRIPTION WAS SHOWING 75 GALLONS, DRAWING TEMPLATE/TABLE UPDATED, WEIGHT/FINISH ADDED	ADH 3/17/10	2007	DRAWN / DATE	MATERIAL
B	5.38 WAS 5.00, BOLT BAG AND BANDS ADDED TO TABLE	ADH 5/13/09	1862	ADH 8/1/07	
A	TOLERANCE WAS 1% @ 68° F	GWC 3/14/07		APPRD. / DATE	
REV	DESCRIPTION	BY / DATE	CCN	REH 11/26/07	
ALL DIMENSIONS ARE IN DECIMAL INCHES TOLERANCES UNLESS OTHERWISE SPECIFIED		THIRD ANGLE PROJECTION ANSI 14.5M		SHOT WEIGHT:	NOTES:
POLYETHYLENE		METAL DECIMAL \pm .125" FRACTION \pm 1/4" ANGLE \pm 1°		SHIPPING WEIGHT: 24 LBS.	
\pm 1% @ 68° F				FINISH: POWDER COATING, BLACK TILE, 40012	



Den Hartog
INDUSTRIES, INC.

Ace Roto-Mold Injection Molding Blow Molding Sowjoy

4010 HOSPERS DRIVE S. BOX 425, HOSPERS, IOWA 51238-0425

DESCRIPTION ① CRADLE FOR 55 GALLON HORIZONTAL TANK	
SCALE N.S.	PART NO. HZ0055-C