

Copyright. All information furnished within this document, electronic file or design correspondence is the property of Den Hartog industries, Inc. and shall not be used, disclosed to others or copied without the expressed written consent of Den Hartog Industries, Inc.

KEY	PART NUMBER	DESCRIPTION	QTY.
1	CB090-30ST-1	PANBASE	2
2	CB090-30ST-2	MIDDLE RING	1
3	CB090-30ST-3	LOWEST RING	1
4	CB090-30ST-4	BENT SUPPORT STRAP	8
5	CB090-30ST-5	CHANNEL RING	1
6	12118	GUSSET	4
7	CB090-30ST-7	ANGLE BRACING	8
8	CB090-30ST-8	BASE CHANNEL (SHORT)	2
9	CB090-30ST-9	CHANNEL BRACE	2
10	CB090-30ST-10	LEG PIPE	4
11	CB090-30ST-11	LEG BASE	4
12	CB090-30ST-12	BASE CHANNEL	2
13	CB090-30ST-13	ROD FILLER	8
14	CB090-30ST-14	ANGLE BRACING (SHORT)	4
15	CB090-30ST-15	TOP RING	1
16	CB090-30ST-16	LEG PLUG	4
17	CB090-30ST-17	CHANNEL BRACE-POWDER COAT	2

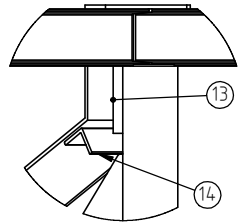

DETAIL D
SCALE 1: 10

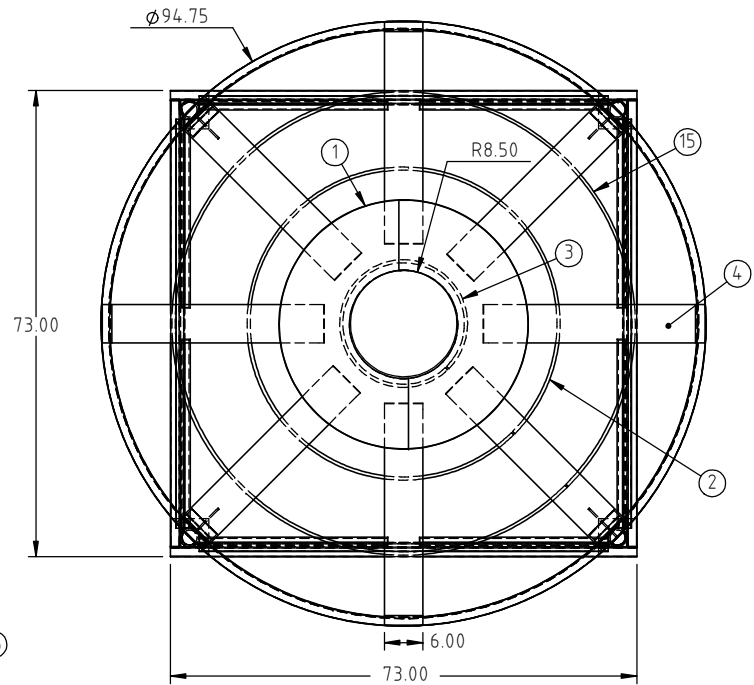
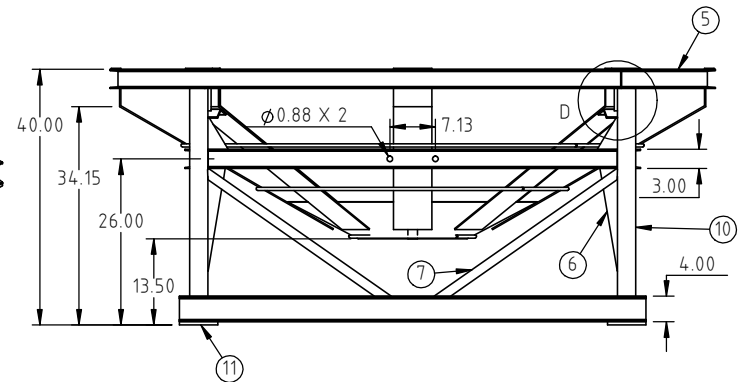
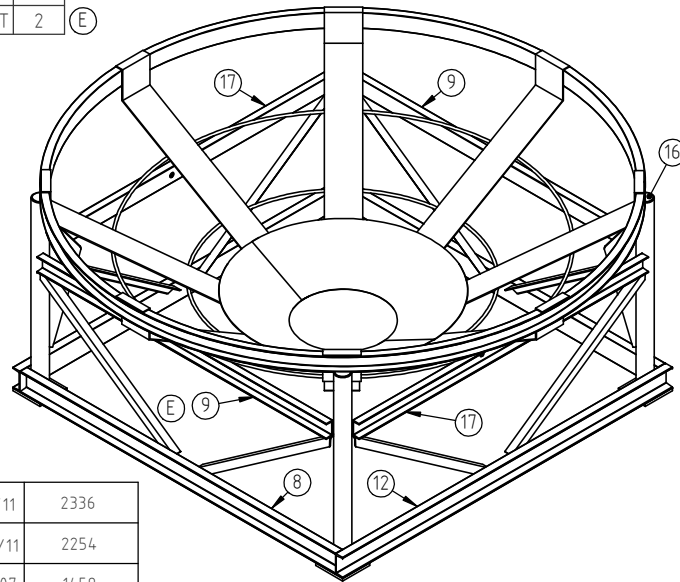

F	ANGLE DETAIL ADDED TO PRINT	ADH 12/8/11	2336
E	HOLES FOR POWDER COATING ADDED TO TWO LEGS COMPONENT TABLE/DRAWING TEMPLATE UPDATED	ADH 7/22/11	2254
D	PART NUMBER CORRECTED	ADH 9/18/07	1459
C	S-14GA UPDATED TO SJCB090 P.B.	GWC 3/8/07	
B	TOLERANCE WAS 1% @ 68°F	GWC 3/8/07	
A	ISOLATED STAND, ADDED B.O.M.	NVE 6/6/06	
REV	DESCRIPTION	BY / DATE	CCN

DRAWN / DATE	MATERIAL
ADH 7/2/07	
APPRD. / DATE	
REH 7/18/07	

SHOT WEIGHT:	NOTES:
SHIPPING WEIGHT:	640.00 LBS
FINISH:	POWDER COATING, BLACK TILE, 40012



Den Hartog
INDUSTRIES, INC.

Ace Roto-Mold Injection Molding Blow Molding Sowjoy

4010 HOSPERS DRIVE S. BOX 425, HOSPERS, IOWA 51238-0421

DESCRIPTION	CONE BOTTOM STAND FOR 30°, 90° TANK		
SCALE	N.S.	PART NO.	CB090-30ST

ALL DIMENSIONS ARE IN DECIMAL INCHES TOLERANCES UNLESS OTHERWISE SPECIFIED	
POLYETHYLENE ±1% @ 68°F	METAL DECIMAL ± .125" FRACTION ± 1/4" ANGLE ± 1°

