

© DEN HARTOG INDUSTRIES, INC.

Copyright. All information furnished within this document, electronic file or design correspondence is the property of Den Hartog industries, Inc. and shall not be used, disclosed to others or copied without the expressed written consent of Den Hartog Industries, Inc.

KEY	PART NUMBER	DESCRIPTION	QTY.
1	IN40-85-ST-1	LEG PIPE	4
2	IN40-85-ST-2	CENTER RING	1
3	IN40-85-ST-3	RING	1
4	12583	1" PIPE PLUG	4
5	IN40-85-ST-5	BASE STRAP	4
6	IN40-85-ST-6	HORIZONTAL SUPPORT BAR	4
7	IN40-85-ST-7	ANGLED SUPPORT STRAP	4

IN40/85-ST

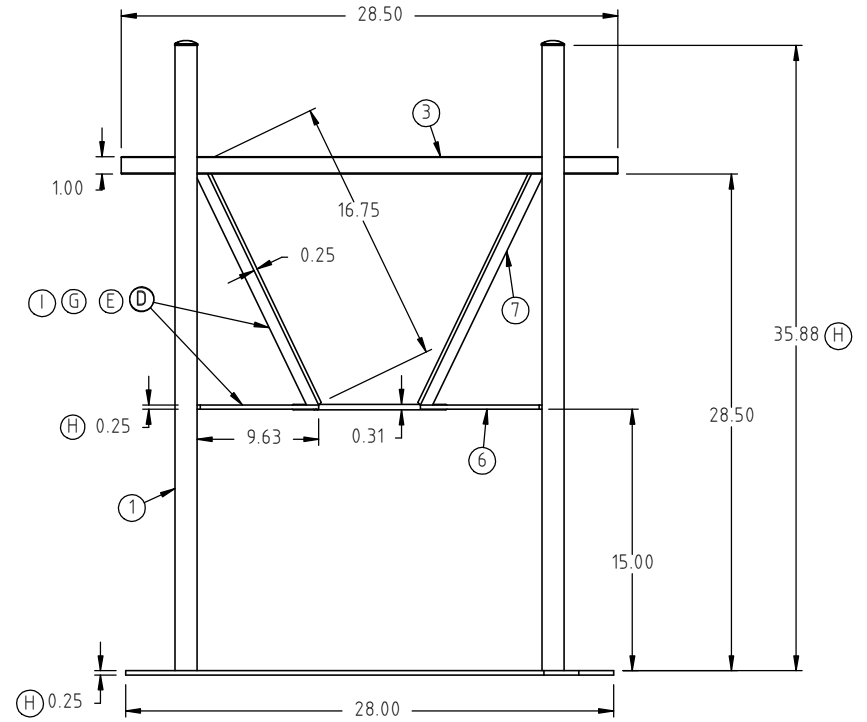
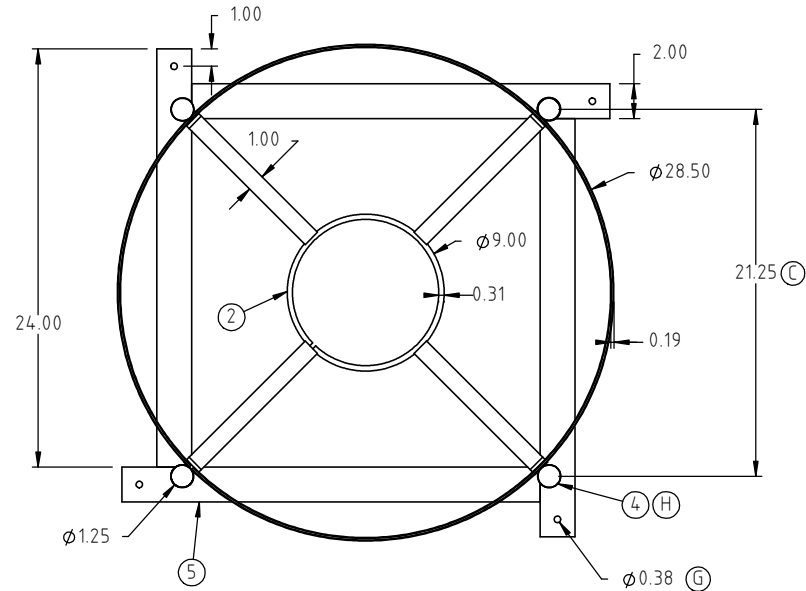
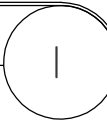

I	9.63" WAS 9.50", 16.75" WAS 16.50". DRAWING TEMPLATE/TABLE UPDATED	ADH 10/25/11	2317
H	DIMENSIONS AND LEG PLUGS UPDATED	ADH 10/14/08	1729
G	HOLE DIA WAS .44 DIA.	ADH 3/28/08	1637
F	CORRECTED PART NUMBER	ADH 10/31/07	1506
E	LENGTH WAS 9.75 AND 17.00	ADH 6/25/07	
D	LENGTH WAS 9.50 AND 16.50	ADH 6/13/07	
C	WAS 21.00	DHJ 6/13/07	
B	TOLERANCE WAS 1% @ 68°F	GWC 3/15/07	
A	ADDED B.O.M.	NVE 6/9/06	
REV	DESCRIPTION	BY / DATE	CCN

DRAWN / DATE	MATERIAL
ADH 7/18/07	
APPRD. / DATE	
REH 10/5/07	

ALL DIMENSIONS ARE IN DECIMAL INCHES  
TOLERANCES UNLESS OTHERWISE SPECIFIED

POLYETHYLENE	METAL DECIMAL ± .125" FRACTION ± 1/4" ANGLE ± 1°
±1% @ 68°F	

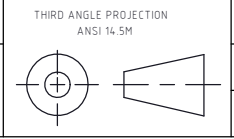

SHOT WEIGHT:	NOTES:
SHIPPING WEIGHT: 40.00 LBS	
FINISH: POWDER COATING, BLACK TILE, 40012	



# Den Hartog

INDUSTRIES, INC.

*Acro Roto-Mold Injection Molding Blow Molding Sowjey*

4010 HOSPERS DRIVE S. BOX 425, HOSPERS, IOWA 51238-0425

DESCRIPTION	
40,85, OR 110 GALLON INDUCTOR STAND	
SCALE	PART NO.
N.S.	IN40/85-ST