

Copyright. All information furnished within this document, electronic file or design correspondence is the property of Den Hartog industries, Inc. and shall not be used, disclosed to others or copied without the expressed written consent of Den Hartog Industries, Inc.

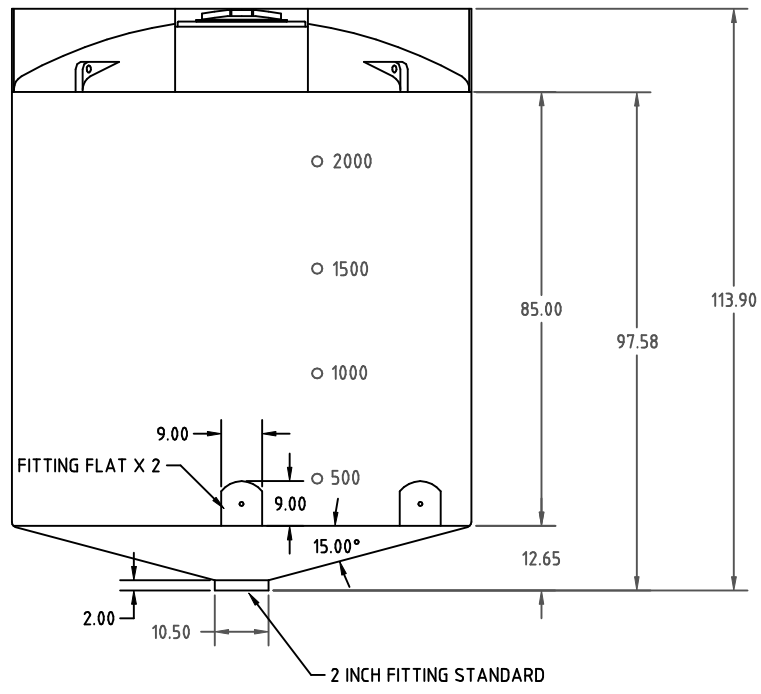

				DRAWN / DATE DHJ 1/5/11 APPRD. / DATE REH 2/2/11	MATERIAL 10420
REV	DESCRIPTION	BY / DATE	CCN		
	ALL DIMENSIONS ARE IN DECIMAL INCHES TOLERANCES UNLESS OTHERWISE SPECIFIED POLYETHYLENE ±1% @ 68° F	THIRD ANGLE PROJECTION ANSI 14.5M 		SHOT WEIGHT: 435 LBS. SHIPPING WEIGHT: 437 LBS. FINISH:	NOTES: 1. THICKNESS @ BOTTOM SIDEWALL .390

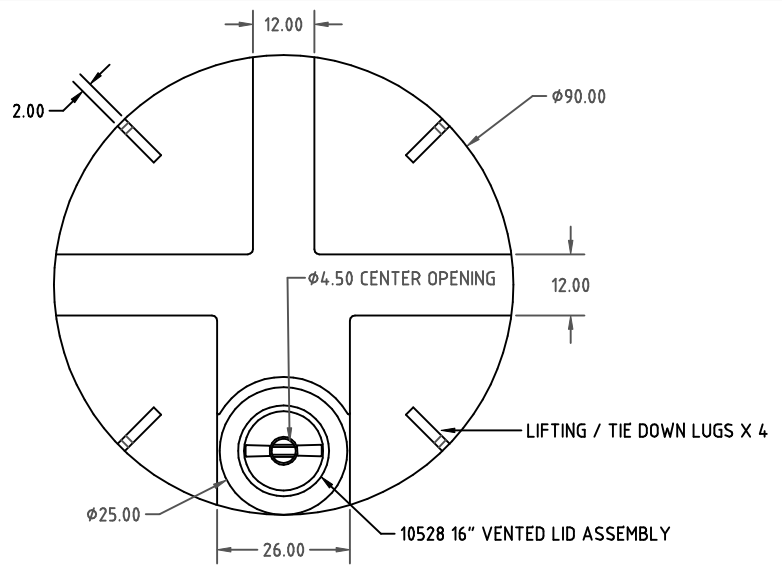

Den Hartog

INDUSTRIES, INC.

Ace Roto-Mold Injection Molding Blow Molding Sowjoy
 4010 HOSPERS DRIVE S. BOX 425, HOSPERS, IOWA 51238-0425

DESCRIPTION 2450 GAL. 90" DIA. X 15° CONE BOTTOM TANK W/ INDUSTRIAL TOP	
SCALE N.S.	PART NO. CB2450-90