

Copyright. All information furnished within this document, electronic file or design correspondence is the property of Den Hartog industries, Inc. and shall not be used, disclosed to others or copied without the expressed written consent of Den Hartog Industries, Inc.

LID TRIM AND FASTENING DETAIL

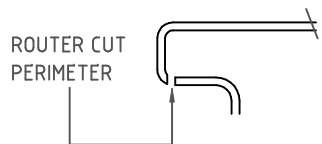

ROUTER CUT PERIMETER

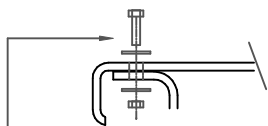

3/8" X 1-1/2" HEX BOLT, 3/8" FLATWASHERS AND HEX NUT 12 PLACES

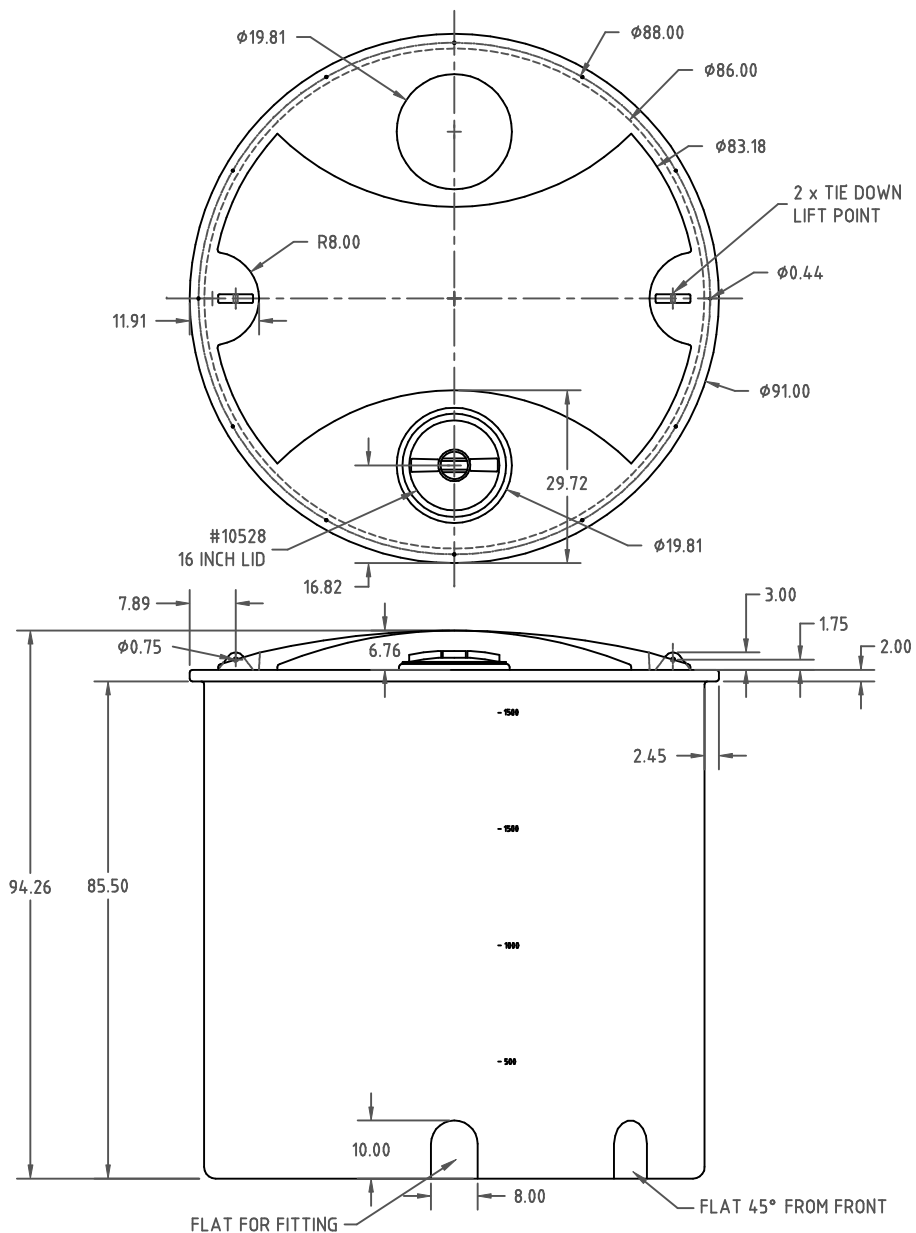

REV	DESCRIPTION	BY / DATE	CCN
ALL DIMENSIONS ARE IN DECIMAL INCHES TOLERANCES UNLESS OTHERWISE SPECIFIED			
POLYETHYLENE		THIRD ANGLE PROJECTION ANSI 14.5M 	
METAL DECIMAL $\pm .125$ " FRACTION $\pm 1/4$ " ANGLE $\pm 1^\circ$			

DRAWN / DATE DHJ 4/29/11 APPRD. / DATE REH 5/10/11	MATERIAL 10420
SHOT WEIGHT: 400 LBS. SHIPPING WEIGHT: 402 LBS. FINISH:	NOTES: 1.370 THICK AT FITTING

Den Hartog

INDUSTRIES, INC.

Ace Roto-Mold Injection Molding Blow Molding Sowjoy
4010 HOSPERS DRIVE S. BOX 425, HOSPERS, IOWA 51238-0425

DESCRIPTION		2060 GALLON OPEN TOP TANK	
SCALE	N.S.	PART NO.	OP2060-86